

# • SPECIFICATION •

## • 6595 - ARMSTRONG DECK MOUNTED SOAP DISPENSER

- Designed for easy installation
- Smooth pump action dispenser
- Easy top fill option or undermount refill
- Soap dispenser bottle capacity 500ml
- Robust UK made pump mechanism
- Optional fitted security screw on soap dispenser head

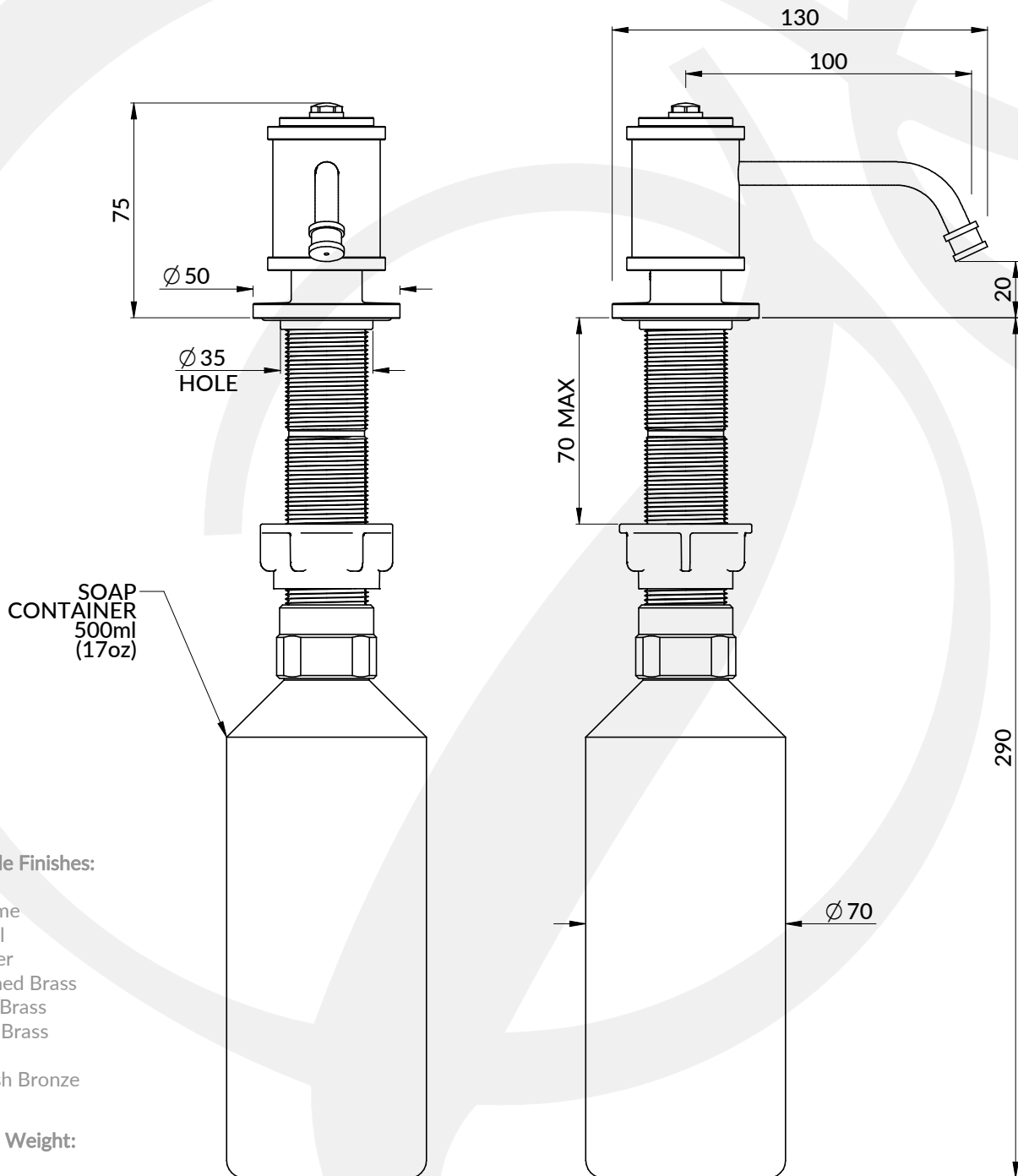
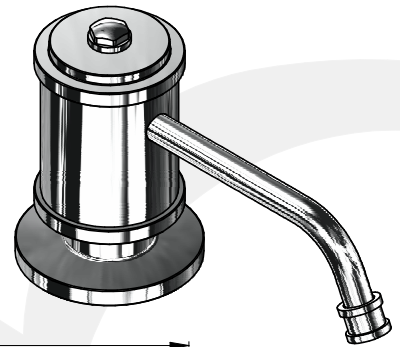

### Available Finishes:

- Chrome
- Nickel
- Pewter
- Polished Brass
- Satin Brass
- Aged Brass
- Gold
- English Bronze

**Packed Weight:**  
2.2 kg